



Torque Motor and Power Controller Package TM Series

OPERATING MANUAL



Thank you for purchasing an Oriental Motor product.

This operating manual describes product handling procedures and safety precautions.

- Please read it thoroughly to ensure safe operation.
- Always keep the manual where it is readily available.

Table of contents

1	Introduction	2	7	Operation	22
2	Safety precautions	4	7.1	Basic operations.....	22
3	Precautions for use.....	6	7.2	Torque setting using an external potentiometer or external DC voltage.....	23
4	Preparation	7	7.3	Timing chart.....	25
4.1	Checking the product	7	7.4	Parallel operation	26
4.2	List of combinations	7	7.5	Adjustment using the torque fine-tuning potentiometer	27
4.3	Names and functions of parts	8	8	Alarm output	28
4.4	Installing/removing the cover	8	8.1	Alarm output signal circuit.....	28
5	Installation.....	9	8.2	Timing chart.....	29
5.1	Location for installation	9	9	Switching between sink logic and source logic.....	30
5.2	Installing the motor.....	9	10	Inspection	33
5.3	Installing the power controller	11	11	Troubleshooting and remedial actions	34
5.4	Mounting the capacitor.....	11	12	Peripheral equipment (sold separately)	35
5.5	Installing and wiring in compliance with EMC Directive.....	11			
6	Connection.....	13			
6.1	Connection terminals	13			
6.2	Connection example	15			
6.3	Connecting the main circuit terminals.....	17			
6.4	Connecting the control circuit terminals.....	18			

1 Introduction

1.1 Before using the motor

Only qualified personnel of electrical and mechanical engineering should work with the product. Use the product correctly after thoroughly reading the section “2 Safety precautions” on p.4. In addition, be sure to observe the contents described in warning, caution, and note in this manual. The product described in this manual has been designed and manufactured to be incorporated in general industrial equipment. Do not use for any other purpose. Oriental Motor Co., Ltd. is not responsible for any damage caused through failure to observe this warning.

1.2 Overview of the product

Power controller torque-controls a torque motor based on open-loop phase control. When an open state of the built-in thermal protector of the motor is detected, the power controller will cause the ALARM LED to blink and turn the alarm output OFF to prevent the motor from restarting upon automatic reset of the thermal protector.

1.3 Standard and CE Marking

■ UL Standards, CSA Standards

The motors are recognized by UL under the UL and CSA Standards. The power controller is recognized by UL under the UL Standards. Model names, which conform to the standards, are the motor model names and the power controller model name.

Applicable Standards

	Applicable Standards	Certification Body / File No.
Motor	UL 1004-1, UL 1004-3 CSA C22.2 No.100, CSA C22.2 No77	UL/E64197
Power controller	UL 508	UL/E91291

■ CCC System

The motors are affixed with the CCC Marking under the China Compulsory Certification System. It is also certified by CQC. Applications standards: GB/T 12350

■ CE Marking

The motors are affixed with the CE Marking under the Low Voltage Directive. The power controller is affixed with the CE Marking under the Low Voltage Directive and the EMC Directive.

- Low Voltage Directive
 - This product is designed and manufactured to be incorporated in equipment.
 - This product cannot be used in IT power distribution systems.
 - Install the product within the enclosure in order to avoid contact with hands.
 - Be sure to ground the Protective Earth Terminal of the motor.
 - Isolate the cable for connecting between the motor and the driver, the power supply cable and other drive cables from the signal cables by means of double insulation.

Applicable Standards

Motor: EN 60034-1, EN 60034-5, EN 60664-1, EN 62368-1

Power controller: EN 50178, EN 62368-1

Installation conditions (EN Standard)

Motor	Power controller
Overvoltage category: II Pollution degree: 2 Protection against electric shock: Class I	Overvoltage category: II Pollution degree: 2 Protection against electric shock: Class II

If the overvoltage category III and pollution degree 3 are required for the equipment, install the motor and power controller in an enclosure whose degree of protection is equivalent to IP54 or higher, and supply a rated voltage via the insulation transformer.

The motor temperature rise tests

Temperature rise tests stipulated in the standards are conducted in a condition where a motor is mounted on a heat radiation plate instead of attaching a gearhead. The size and material for the heat radiation plates are as follows.

Motor model	Size [mm (in.)]	Thickness [mm (in.)]	Material
2TK3	115 × 115 (4.53 × 4.53)	5 (0.20)	Aluminum alloy
3TK6	125 × 125 (4.92 × 4.92)		
4TK10	135 × 135 (5.31 × 5.31)		
5TK20	165 × 165 (6.50 × 6.50)		

Thermal class EN Standards: 130 (B)

- **EMC Directive**

This product has received EMC measures under the conditions specified in "Example of installation and wiring" on p.12. Be sure to conduct EMC measures with the product assembled in your equipment by referring to "5.5 Installing and wiring in compliance with EMC Directive" on p.11.

Applicable Standards

EMI	EN 61000-6-4 EN 55011 Group 1 Class A
EMS	EN 61000-6-2

Caution: This equipment is not intended for use in residential environments nor for use on a low-voltage public network supplied in residential premises, and it may not provide adequate protection to radio reception interference in such environments.

■ Republic of Korea, Radio Waves Act.



KC Mark is affixed to this product under the Radio Waves Act, the republic of Korea.

■ RoHS Directive

The products do not contain the substances exceeding the restriction values of RoHS Directive (2011/65/EU).

2 Safety precautions

The precautions described below are intended to prevent danger or injury to the user and other personnel through safe, correct use of the product. Use the product only after carefully reading and fully understanding these instructions.

 Warning	Handling the product without observing the instructions that accompany a “Warning” symbol may result in serious injury or death.
 Caution	Handling the product without observing the instructions that accompany a “Caution” symbol may result in injury or property damage.
Note	The items under this heading contain important handling instructions that the user should observe to ensure safe use of the product.

 Warning
--

General

- Do not use the product in explosive or corrosive environments, in the presence of flammable gases, locations subjected to splashing water, or near combustibles. Doing so may result in fire, electric shock or injury.
- Only qualified and educated personnel should be allowed to perform installation, connection, operation and inspection/troubleshooting of the product. Handling by unqualified and uneducated personnel may result in fire, electric shock, injury or equipment damage.
- Do not transport, install the product, perform connections or inspections when the power is on. Always turn the power off before carrying out these operations. Failure to do so may result in electric shock.

Installation

- The motor is Class I equipment. Install the motor so as to avoid contact with hands, or ground it to prevent the risk of electric shock.
- Install the motor and power controller in their enclosures in order to prevent electric shock or injury.

Connection

- The supply voltage input to the power controller should correspond to the supply voltage specification of the motor. If the two power supplies do not match, fire or equipment damage may occur.
- As for the DC power supply (+24 V) for the control circuit of the power controller, use a power supply with overcurrent protection function, or install an overcurrent protection device (such as a fuse) in the output section. Failure to take these measures may result in fire or equipment damage.
- Connect the cables securely according to the wiring diagram in order to prevent fire and electric shock.
- Do not forcibly bend, pull or pinch the read wire, cable. Doing so may result in fire and electric shock.
- Be sure to observe the specified cable sizes. Use of unspecified cable sizes may result in fire.
- Be sure to insulate the connection terminal of the capacitor. Failure to do so may result in electric shock.
- To prevent electric shock, be sure to install the power controller’s after making connections.

Operation

- Turn off the power in the event of a power failure, or the motor may suddenly start when power is restored and may cause injury or damage to equipment.
- Turn off the power in the event the overheat protection device (thermal protector) is triggered. Failure to do so may result in injury or damage to equipment, since the motor will start abruptly when the overheat protection device (thermal protector) is automatically reset.
- Do not change the power frequency while the power controller is receiving power. Doing so may result in fire or equipment damage.

Maintenance and inspection

- Do not touch the terminal block of the power controller’s motor and power immediately after the power is turned off (for a period of 1 minute). This may cause electric shock.

Repair, disassembly and modification

- Do not disassemble or modify the motor, power controller. This may cause electric shock or injury.

 **Caution**
General

- Do not use the motor, power controller beyond its specification, or electric shock, injury or damage to equipment may result.
- Do not hold the motor output shaft or motor lead wires. This may cause injury.
- If the alarm output of the power controller has turned OFF, remove the cause of the problem and then reset the alarm. Failure to do so may result in injury or equipment damage.

Installation

- Keep the area around the motor, power controller free of combustible materials in order to prevent fire or burning.
- Keep the area around the motor, power controller free of combustible materials in order to prevent fire or a skin burn(s).

Connection

- Do not install an electromagnetic contactor or power relay between the motor and power controller. If the direction is switched between forward and reverse using an electromagnetic contactor, etc., equipment damage may occur.

Operation

- Use a power controller and motor only in the specified combination. An incorrect combination may cause a fire.
- Provide an emergency stop device or emergency stop circuit external to the equipment so that the entire equipment will operate safely in the event of a system failure or malfunction. Failure to do so may result in injury.
- Turn on the power to the power controller after turning OFF the CW input and CCW input (to stop the motor). Failure to do so may cause the motor to start suddenly and result in injury or equipment damage.
- Immediately when trouble has occurred, stop running and turn off the power controller power. Failure to do so may result in fire, electric shock or injury.
- The power controller allows for easy adjustment of motor torque. Before starting the inverter, thoroughly check the allowable speed ranges of the motor and equipment. Failure to do so may result in injury.
- To prevent bodily injury, do not touch the rotating parts (output shaft) of the motor during operation.
- The motor surface temperature may exceed 70 °C (158 °F) even under normal operating conditions. If the operator is allowed to approach a running motor, attach a warning label as shown in the figure in a conspicuous position. Failure to do so may result in skin burn(s).



Warning label

Inspection







- Conduct the insulation resistance measurement or withstand voltage test separately on the motor and the power controller. Conducting the insulation resistance measurement or withstand voltage test with the motor and power controller connected may result in injury or damage to equipment.
- Do not touch the terminals during the insulation resistance measurement or withstand voltage test. Failure to do so may result in electric shock.

Disposal

- Dispose the product correctly in accordance with laws and regulations, or instructions of local governments.

■ Warning labels

Warnings are indicated on the cover of the power controller. Always observe such information when handling the power controller.

	WARNING — Risk of electric shock.
	• Read manual before installing. • Wait 1 minute for capacitor discharge after disconnecting power supply.
	AVERTISSEMENT — Risque de décharge électrique.
	• Lire le manuel avant l'installation. • Attendre 1 minute après la coupure de l'alimentation, pour permettre la décharge des condensateurs.
	警告 — けが・感電のおそれがあります。
	• 据え付け、運転の前には必ず取扱説明書をお読み下さい。 • 通電中及び電源遮断後1分以内はカバーを外さないで下さい。

3 Precautions for use

This chapter explains the limitations and other items the user must note when using the motor, power controller.

- **Always use the power controller with Oriental Motor’s torque motor.**
Check the permitted power controller/motor combinations in “4.3 Names and functions of parts” on p.8.
- **If your equipment needs to be able to actuate an emergency stop of the motor, provide a mechanical function to stop the motor and hold its position.**

Once the thermal protector of the motor is actuated (becomes open), output from the power controller will stop. However, the protective function alone cannot stop the motor immediately. If your equipment needs to be able to actuate an emergency stop of the motor, provide a mechanical function to stop the motor and hold its position.

- **Do not install an electromagnetic contactor or power relay between the motor and power controller.**

If the direction is switched between forward and reverse using an electromagnetic contactor, etc., the power controller may be damaged.

- **Connect a protective device to the primary power circuit.**

Install a protective device between the power supply and inverter to protect the inverter’s primary circuit. For details on selecting an appropriate protective device for this purpose, refer to the following to select a protective device.

Circuit breaker or earth leakage breaker

Motor rated voltage	Single-phase 100-115 V	Single-phase 200-230 V
Ratings of protective device	125 VAC 5 A (quick cutoff type)	250 VAC 3 A (quick cutoff type)

If an earth leakage breaker is to be used, use one with a current sensitivity of 10 mA or more.

- **Cable size and wiring distance**

Use a power cable and motor cable of AWG18 to 14 (0.75 to 2.0 mm²) in size.

The maximum extendable wiring distance between the motor and power controller is 20 m (65.6 ft.). If the wiring distance between the power controller and motor must exceed 20 m (65.6 ft.), please contact your nearest Oriental Motor branch or sales office.

Minimize the length of the signal cable. Also, wire the control lines away from the main circuits, relay sequence circuits and other high-power circuits of peripherals, in order to prevent induction by peripherals.

- **Noise elimination**

See “5.5 Installing and wiring in compliance with EMC Directive” on p.11 for measures with regard to external noise.

- **Grease measures**

On rare occasions, grease may ooze out from the gearhead. If there is a concern over possible environmental damage resulting from the leakage of grease, provide an oil tray or similar oil catching mechanism in order not to cause a secondary damage.

Grease leakage may lead to problems in the customer’s equipment or products.

4 Preparation

This section covers the points to be checked along with the names and functions of the respective parts.

4.1 Checking the product

Verify that the items listed below are included. Report any missing or damaged items to the branch or sales office from which you purchased the product.

Confirm the model of the unit against the model name shown on the package label.

Confirm the models of the motor, gearhead and power controller against the model names shown on their respective nameplates.

- Motor..... 1 unit
- Power controller..... 1 unit
- Capacitor..... 1 piece
- Capacitor cap..... 1 piece
- OPERATING MANUAL..... 1 copy

Combination type only

- Mounting screw set..... 1 set
(Mounting screws, hexagonal nuts, washers,
spring washers 4 pieces each, parallel key 1 piece.)*
- * The mounting screw set is not supplied with motors
having no key grooves on the output shaft.

4.2 List of combinations

Model names for motor, capacitor, gearhead and power controller are shown below.

- “■” in the unit model represents a number indicating the gear ratio for combination types. This symbol is “GN” for pinion shaft types, and “A” for round shaft types. “□” in the gearhead model represents a number indicating the gear ratio.
- “S” in the unit model is appended only for combination types.
- With round shaft types, “GN” in the motor model is replaced by “A.”
- On combination types, the motor and gearhead come preassembled.
- Gearheads are sold separately for pinion shaft types.

- 100/110/115 V type

Model name	Motor model	Capacitor model	Gearhead model	Power controller model
TM203A-■SJ	2TK3GN-AW2	CH70CFAUL2	2GN□S	TMP-1
TM203A-■SU		CH60CFAUL2		
TM306A-■SJ	3TK6GN-AW2	CH110CFAUL2	3GN□S	
TM306A-■SU		CH90CFAUL2		
TM410A-■SJ	4TK10GN-AW2	CH140CFAUL2	4GN□S	
TM410A-■SU		CH110CFAUL2		
TM520A-■SJ	5TK20GN-AW2	CH180CFAUL2	5GN□S	
TM520A-■SU		CH140CFAUL2		

- 200/220/230 V type

Model name	Motor model	Capacitor model	Gearhead model	Power controller model
TM203C-■SJ	2TK3GN-CW2	CH18BFAUL	2GN□S	TMP-1
TM203C-■SE		CH15BFAUL		
TM306C-■SJ	3TK6GN-CW2	CH30BFAUL	3GN□S	
TM306C-■SE		CH25BFAUL		
TM410C-■SJ	4TK10GN-CW2	CH35BFAUL	4GN□S	
TM410C-■SE		CH30BFAUL		
TM520C-■SJ	5TK20GN-CW2	CH45BFAUL	5GN□S	
TM520C-■SE		CH40BFAUL		

4.3 Names and functions of parts

The figure shows a view with the cover removed. After connection, be sure to install the cover.

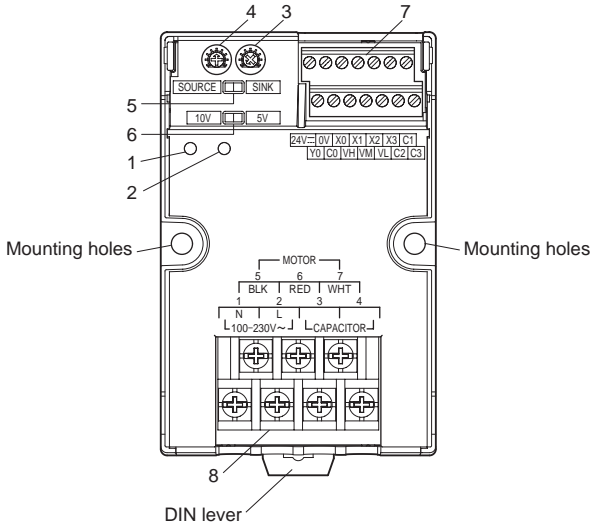

No.	Name	Description
1	POWERLED (green)	This LED will be lit when the AC power supply is input to the power controller.
2	ALARM LED (red)	This LED will blink when an alarm occurs. The ALARM output will become OFF (H level). (→ p.28)
3	Internal torque potentiometer (TORQUE)	This potentiometer is used to set the motor torque. (→ p.22)
4	Torque fine-tuning potentiometer (ADJUST)	This potentiometer is used to fine-tune the variation in motor torque relative to the torque setting. (→ p.27)
5	Sink/source input selector switch	Used for switching the input circuit between sink and source logic modes. (→ p.30)
6	External DC voltage select switch	When external DC voltage is used to set the torque, change the setting of this switch in accordance with the actual external DC voltage to be used. Select either 5 V or 10 V. (→ p.24)
7	Control circuit terminal	Connect the control DC power supply and I/O signal cable. (→ p.14)
8	Main circuit terminal	Connect the AC power supply, motor and capacitor. (→ p.13)

4.4 Installing/removing the cover

- How to remove the cover
Pull the cover strongly toward you, and the cover will come off.
- How to install the cover
 1. Insert the two hooks at the bottom of the cover into the corresponding holes in the controller body.
 2. Push in the cover by using the two tabs at the top of the cover as guides.
Push in the cover all the way until you hear a “click”

5 Installation

This chapter explains the installation location and installation methods of the motor, power controller, as well as how to install a load. The installation and wiring methods in compliance with the EMC Directive are also explained.

5.1 Location for installation

This motor, power controller is designed and manufactured for installation in equipment.

Install it in a well-ventilated place satisfying the following conditions, where the inverter can be inspected easily:

- Inside an enclosure installed indoors
- Operating ambient temperature
 - Motor: 100 V, 200 V -10 to +50 °C (+14 to +122 °F) (non-freezing)
 - 110/115 V, 220/230 V -10 to +40 °C (+14 to +104 °F) (non-freezing)
 - Power controller: 0 to +50 °C (+32 to +122 °F) (non-freezing)
- Operating ambient humidity 85% or less (non-condensing)
- Area that is free of explosive atmosphere or toxic gas (such as sulfuric gas) or liquid
- Area free from combustibles
- Area not exposed to direct sun
- Area free of excessive amount of dust, iron particles or the like
- Area not subject to splashing water (rain, water droplets), oil (oil droplets) or other liquids
- Area free of excessive salt
- Area not subject to continuous vibration or excessive shocks
- Area free of excessive electromagnetic noise (from welders, power machinery, etc.)
- Area free of radioactive materials, magnetic fields or vacuum
- Altitude of 1000 m (3300 ft.) or less

5.2 Installing the motor

■ Combination type

Drill holes on the mounting plate and fix the motor and gearhead on the plate using four screws (supplied).

Pay attention not to create a gap between the motor/gearhead assembly and the installation surface.

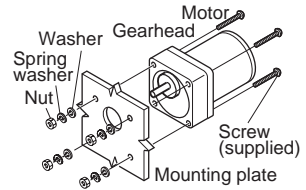

■ Pinion shaft type

Drill holes on the mounting plate and fix the motor and gearhead on the plate using screws supplied with the gearhead. Be careful there is no gap between the motor flange and the gearhead.

For details of installation, see the operating manual supplied with the gearhead, which is sold separately.

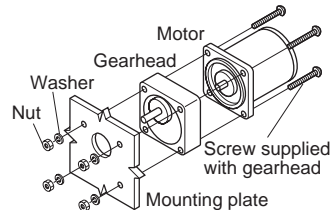

Note Use the gearhead with pinion shaft which is identical with one of motor.

■ Round shaft type

Drill holes on the mounting plate and fix the motor on the plate using screws, nuts, and washers (not supplied). Be careful there is no gap between the motor installation surface and the bracket.

Motor model	Nominal diameter of screw	Tightening torque [N·m (lb-in)]
2TK3	M4	2.0 (17.7)
3TK6	M5	2.5 (22)
4TK10		
5TK20	M6	3.0 (26)

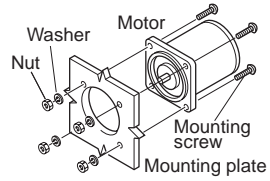

Note Do not insert the motor into the mounting hole at an angle or force it in, as this may scratch the flange pilot section and damage the motor.

■ Attaching load

To shaft of the gearhead has been machined to an outer diameter tolerance of h7 and is provided with a key slot for connecting the transmission parts.

(The **2GN** type has a surface cut by milling.)

When connecting the transmission parts, ensure that the shaft and parts have a clearance fit, and always fix the parallel key to the output shaft with a screw to prevent the parts from rattling or spinning.

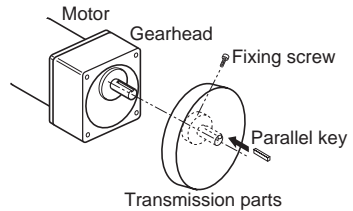

Note Do not use excessive force, or hammer the transmission parts onto the gearhead shaft as damage may occur.

■ Removing/Installing the gearhead

See the following steps to replace the gearhead or to change the outlet position of the lead wires.

Removing the gearhead from the motor

Remove the hexagonal socket head screws (2 pieces) assembling the motor and gearhead and detach the motor from the gearhead.

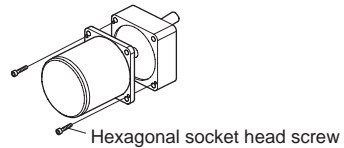

Installing the gearhead to the motor

1. Keep the pilot sections of the motor and gearhead in parallel, and assemble the gearhead with the motor while slowly rotating it clockwise/counterclockwise. At this time, note so that the pinion of the motor output shaft does not hit the side panel or gears of the gearhead strongly.

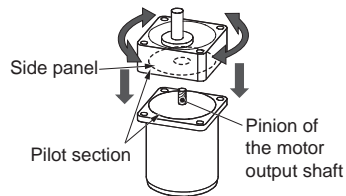

Assemble the gearhead to the motor in a condition where the motor output shaft is in an upward direction.

2. Check no gaps remain between the motor and gearhead, and tighten them with hexagonal socket head screws (2 pieces).

After the motor and gearhead have been assembled, install the motor/gearhead assembly using mounting screws by referring to the explanation under "Combination type" on p.9.

Note

- Do not forcibly assemble the motor and gearhead. Also, do not let metal objects or other foreign matters enter the gearhead. The pinion or gear of the motor output shaft may be damaged, resulting in noise or shorter service life.
- The hexagonal socket head screws used to assemble the motor and gearhead together only tentatively secure the two components. Always use the four supplied mounting screws when installing the motor/gearhead assembly.

5.3 Installing the power controller

Install the power controller on a DIN rail or secure the controller directly onto the target structure using screws installed through the two mounting holes provided in the controller body.

■ Installation on DIN rail

Use a DIN rail 35 mm (1.38 in.) wide to mount the power controller. When removing from DIN rail, pull the DIN lever.

■ Using screws

Secure the power controller with two screws (M4: not supplied) through the two mounting holes provided. Tightening torque: 0.7 N·m (6.2 lb-in)

5.4 Mounting the capacitor

Mount the capacitor securely by using M4 screws (not provided).

Note

- Do not let the screw fastening torque exceed 1 N·m (8.8 lb-in) to prevent damage to the mounting foot.
- Mount capacitor at least 10 cm (3.94 in.) away from the motor. If it is located closer, the life of the capacitor will be shortened.

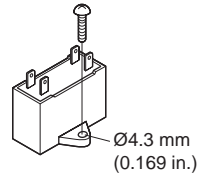

5.5 Installing and wiring in compliance with EMC Directive

This motor, power controller is designed and manufactured for installation in equipment. The requirements of the EMC Directives must be satisfied by the user's equipment in which the inverter is assembled.

The following explains the basic methods for installing/wiring the motor, power controller that are effective in achieving conformance to the EMC Directives by your mechanical equipment.

Please note that the final conformance of your mechanical equipment to the EMC Directives will be determined, among others, by the configuration, wiring, installation condition and degree of hazard of the motor and other control system equipment or electrical parts used with the power controller. Therefore, it is imperative that the user conducts EMC tests on their mechanical equipment to confirm the actual EMC performance level of the equipment.

Unless effective measures are provided to reduce the EMI (electromagnetic interference) caused by the power controller in the control system equipment located nearby, or the power controller's EMS (electromagnetic susceptibility), EMI/EMS can become a serious hindrance to the function of the user's mechanical equipment. Refer to the installation/wiring methods explained on the following pages to provide appropriate measures required for conformance to the EMC Directive.

■ Connecting a mains filter for power supply line

Connect a mains filter in the AC input line to prevent the noise generating in the power controller from irradiating out via the power supply lines.

Use the following product or an equivalent mains filter.

Manufacturer	Model
Schaffner EMC	FN2070-10-06
SOSHIN ELECTRIC CO., LTD	NF2010A-UP

- Install the mains filter at a position as close as possible to the inverter. Also, use cable clamps, etc., to securely affix the input and output cables of the mains filter to the enclosure in order to prevent the cables from separating from the enclosure surface. Use as thick a cable as possible to connect the grounding terminal of the mains filter to a grounding point over the minimum distance.
- Do not wire the AC input cable and the mains filter's output cable in parallel. Doing so may allow the noise in the enclosure to enter the power supply cable via stray capacitance and compromise the effect of the mains filter.

■ Connecting surge arrester

Use a surge arrester or equivalent as below.

Manufacturer	Model
SOSHIN ELECTRIC CO., LTD	LT-C12G801WS
OKAYA ELECTRIC INDUSTRIES CO., LTD.	R-C-M-601BQZ-4
PHOENIX CONTACT GmbH & Co. KG	VAL-MS 230 VF ST

Note When measuring dielectric strength of the equipment, be sure to remove the surge arrester, or the surge arrester may be damaged.

■ Grounding methods

To prevent an electric potential difference from generating at a grounding point, ground each of the motor and mains filter over the minimum distance using as thick a cable as possible. Provide a wide, thick and uniform conductive surface at each grounding point.

■ Connecting the motor cable

Connect the motor using a cable of 20 m (65.5 ft.) or shorter. For the connection method, refer to “6.3 Connecting the main circuit terminals” on p.17.

■ Wiring the control cable

Wire each control cable of the power controller over the minimum distance using a shielded cable. For the applicable cable, refer to “6.4 Connecting the control circuit terminals” on p.18.

■ Wiring a shielded cable

Ground each shielded cable using a metal cable clamp that contacts the entire periphery of the shielded cable and connect it to an appropriate grounding point.

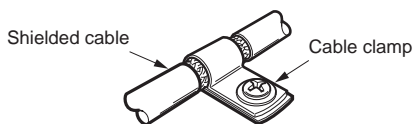

■ Notes about installation and wiring

- Connect the motor directly to their grounding points so as not to generate difference in grounding electrical potential between the motor/inverter and control system equipment nearby.
- If a relay or electromagnetic switch is used with the inverter, connect a mainsfilter or surge absorber to absorb any surge voltage that may generate from the relay or electromagnetic switch.
- Minimize the wiring length of each cable and do not loop or bundle any extra length.
- Wire the power cables such as the motor cable and power supply cable separately from the control cables, and keep a minimum distance of 100 mm (3.94 in.) between the two sets of cables. Also keep as much distance as possible between the AC input cable and output cable of the mains filter.

■ Example of installation and wiring

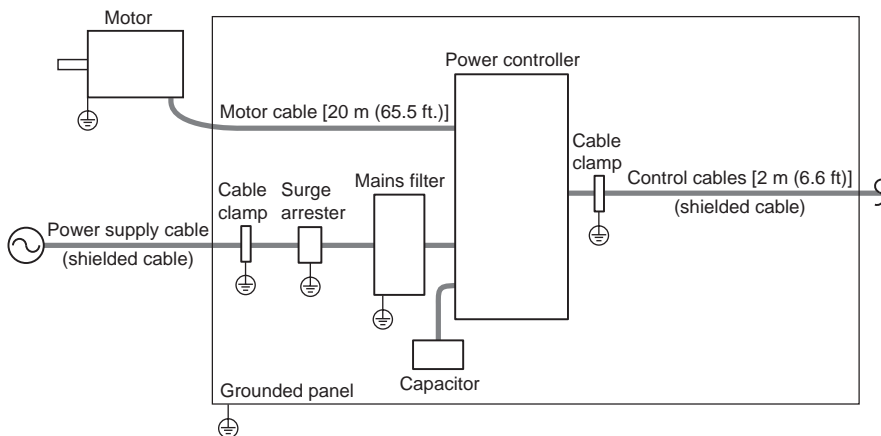

6 Connection

This chapter explains the connection method of the power controller, power supply and motor as well as the connection example.

6.1 Connection terminals

The figure shows a view with the cover removed. After connection, be sure to install the cover.

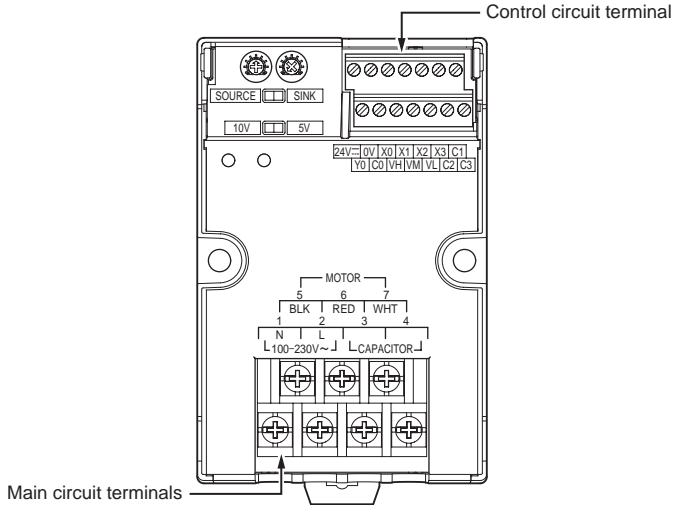

- Main circuit terminals

Terminal No.	Terminal name	Name	Description
1	N	AC power supply connection terminal	Connect the AC power supply. N: neutral, L: live
2	L		
3	CAPACITOR	Capacitor connection terminal	Connect the capacitor.
4			
5	BLK	Motor connection terminal	Connect the motor. BLK: black, RED: red, WHT: white
6	RED		
7	WHT		

Connection

- Control circuit terminal

Terminal No.	Name	Description
24V 	+DC24 V	Connect the DC power supply (24 V) for control circuit.
0V	0 V	
X0	CW input	Control the rotating direction of the motor and run/stop actions. If both inputs are turned ON simultaneously, the motor will stop.
X1	CCW input	
X2	INT/EXT switching input	Switch between external and internal torque potentiometer.
X3	ALARM RESET input	Clear the alarm condition.
C1	IN-COM0	Sink: 0 V / Source: 24 V (The polarity changes according to whether the sink logic or source logic is selected.)
Y0	ALARM output	Output the alarm signals. Once generated, an alarm will be held until it is reset (26.4 V, 40 mA or less).
C0	OUT-COM	This output remains ON (L level) in a normal condition, and will turn OFF (H level) when an alarm occurs.
VH	VH input	Torque can be set using the external torque potentiometer or external DC voltage.
VM	VM input	
VL	VL input	
C2	IN-COM1 (0 V)	
C3		

Note

- As for the DC power supply (+24 V) for the control circuit of the power controller, use a power supply with overcurrent protection function, or install an overcurrent protection device (such as a fuse) in the output section. Failure to take these measures may result in fire or equipment damage.
- If the internal power supply is used while the source logic is selected, do not connect anything to the C2 and C3 terminals. If these terminals are shorted due to miswiring, the power controller may be damaged.

6.2 Connection example

■ Sink logic: SINK/SOURCE input selector switch is set to the SINK position.

The connection example explained in this section assumes that the motor is operated using relays and switches.

An DC power supply (24 VDC) is needed to control the power controller.

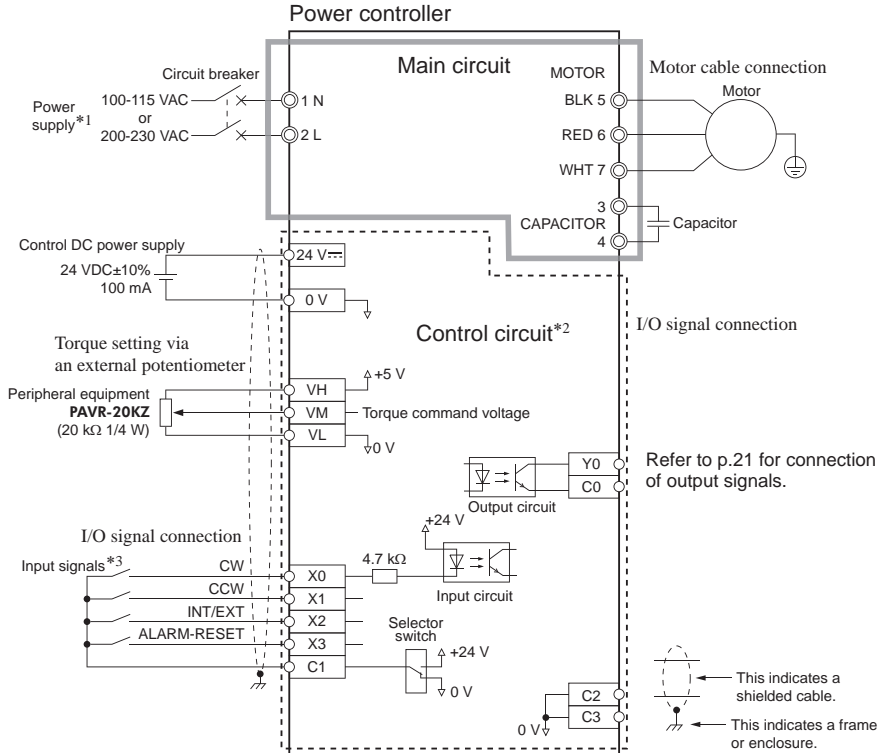

*1 Power-supply input for the power controller should be the same as the power supply voltage of the motor.

*2 The control circuit is a SELV circuit. It is isolated from dangerous voltages by means of protective isolation based on reinforced insulation. The power supply and other devices connected to the control circuit terminals should be isolated from dangerous voltages by reinforced insulation.

*3 The input signals X0 to X3 and C1 are based on sequence connection of mechanical contact or sink transistor type.

Note that the mechanical contacts and transistors connected to the input signals X0 to X3 should have a leak current of not more than 1 mA.

■ **Source logic:**

SINK/SOURCE input selector switch is set to the SOURCE position.

The connection example explained in this section assumes that the motor is operated using relays and switches.

An DC power supply (24 VDC) is needed to control the power controller.

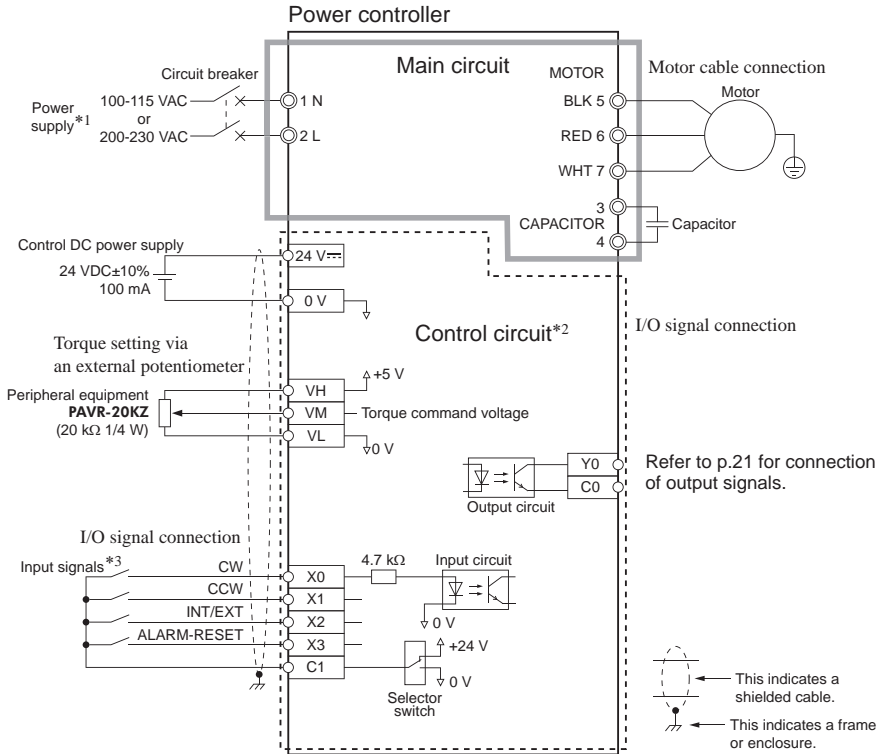

*1 Power-supply input for the power controller should be the same as the power supply voltage of the motor.

*2 The control circuit is a SELV circuit. It is isolated from dangerous voltages by means of protective isolation based on reinforced insulation. The power supply and other devices connected to the control circuit terminals should be isolated from dangerous voltages by reinforced insulation.

*3 The input signals X0 to X3 and C1 are based on sequence connection of mechanical contact or source transistor type.

Note that the mechanical contacts and transistors connected to the input signals X0 to X3 should have a leak current of not more than 1 mA.

6.3 Connecting the main circuit terminals

Connect the AC power supply, motor and capacitor to the corresponding main circuit terminals using round crimp terminals with insulating cover.

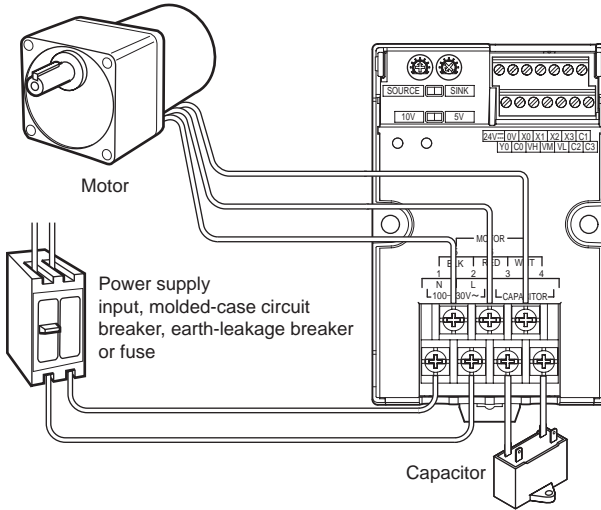

Terminal thread size and applicable cable size

Position	Terminal thread size	Tightening torque	Applicable cable size *
Power connection terminal and cable	M3.5	0.9 to 1.0 N·m (8.0 to 9.0 lb·in)	AWG18 to 14 (0.75 to 2.0 mm ²)
Motor connection terminal and cable			AWG20 to 14 (0.5 to 2.0 mm ²)

* The cable size specified above is based on an assumed maximum ambient temperature of 60/75 °C (140/167 °F) and use of copper wire.

Applicable crimp terminal: Round terminal with insulating cover

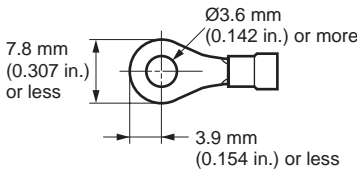

If your equipment is to be sold as a UL certified product, also use certified crimp terminals and cables.

Connecting the AC power supply

Connect the neutral side of the power cable to the N terminal, and connect the live side to the L terminal.

Note To prevent damage to the product or AC power supply due to miswiring, connect the protective device shown on p.6 to the power line.

■ Grounding the motor

Ground the motor using the motor's Protective Earth Terminal (⊕).
 Applicable crimp terminal: Round crimp terminal with insulation cover
 Thread size of terminal: M4
 Tightening torque: 1.0 to 1.3 N·m (8.8 to 11.5 lb-in)
 Applicable lead wire: AWG18 (0.75 mm²) or thicker

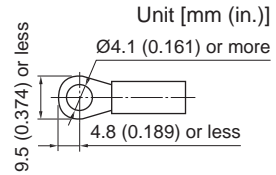

Note | Do not use screws other than the protective earth terminal screws attached on the product.

■ Connecting the motor

Connect the black, red and white leads on the motor to the BLK, RED and WHT motor terminals on the power controller, respectively. Ground the motor using the motor's protective earth terminal.

■ Capacitor connection

The capacitor internal wiring as follows:
 Capacitor terminals are internally electrically connection in twos; A-B and C-D for easy connection. For easy to install terminals use 187 series FASTON terminals (TE Connectivity). Use the supplied capacitor cap to insulate the capacitor terminal connection.

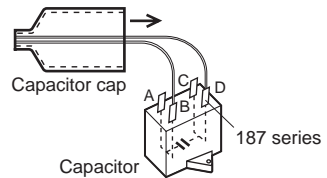

Note | For lead wire connection, use one lead wire for each individual terminal.

6.4 Connecting the control circuit terminals

Keep the lengths of cables to 2 m (6.6 ft.) or less and wire them away from the power lines. To allow torque setting via external signals, use a twisted-pair shielded cable, shielded cable, etc.
 Strip the signal cable by 5.5 mm (0.22 in.) from the end.

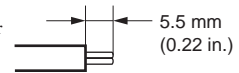

■ Terminal thread size and applicable cable size

Terminal thread size	Tightening torque	Applicable cable size
M2	0.17 to 0.28 N·m (1.5 to 2.5 lb-in)	AWG26 to 16 (0.14 to 1.25 mm ²)

When using crimp terminals, use the following products.

Manufacturer	Part number	Applicable wire size
PHOENIX CONTACT GmbH & Co. KG	AI0.5-6	AWG20 (0.5 mm ²)
	AI0.75-6	AWG18 (0.75 mm ²)

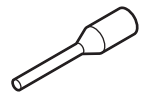

Input signal circuit

The input signals of this inverter are photo-coupler inputs. All control circuit terminals are isolated from dangerous voltages based on reinforced insulation. If a relay is connected to the input circuit, select a small-capacity contact-type relay that can switch 24 VDC, 10 mA. When using an external control device, make sure its leak current is 1 mA or less and ON voltage is 1.6 V or less.

The default setting is sink logic. Use the SINK/SOURCE input selector switch to switch between the sink logic and source logic in accordance with the external control device to be used. Refer to p.30 for logic switching, and p.31 for connection example of input circuit.

- Sink logic SOURCE  SINK

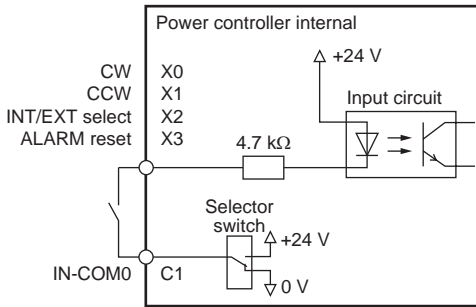

- Source logic SOURCE  SINK

Note | Do not short C1 terminal and C2 and C3 terminals. The power controller may be damaged.

Connection example 1:
Using an internal power supply

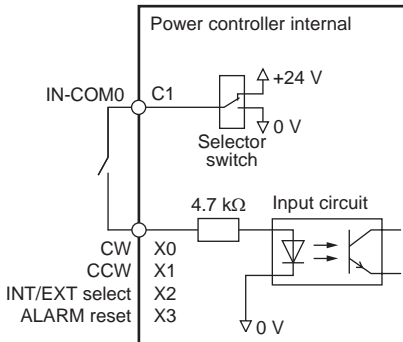

Connection example 2:
Using an external power supply

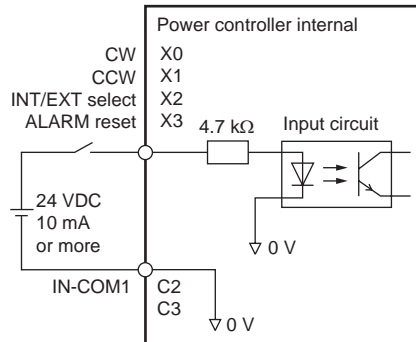

Connection

- **Connecting external DC voltage**

The default setting is 0 to 5 VDC. If the external DC voltage used is in a range of 0 to 10 VDC, set the external voltage selection switch to 10 V (Refer to p.24).

The input impedance (circuit) varies depending on each setting.

Voltage setting of 0 to 10 VDC

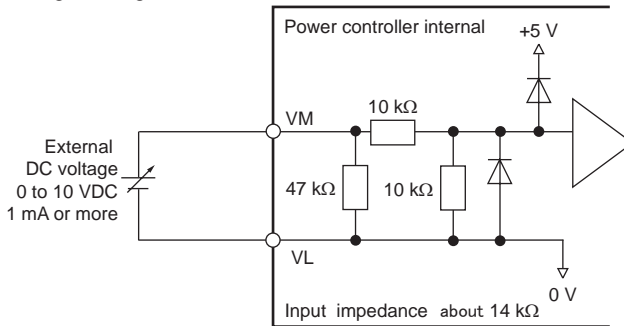

Voltage setting of 0 to 5 VDC

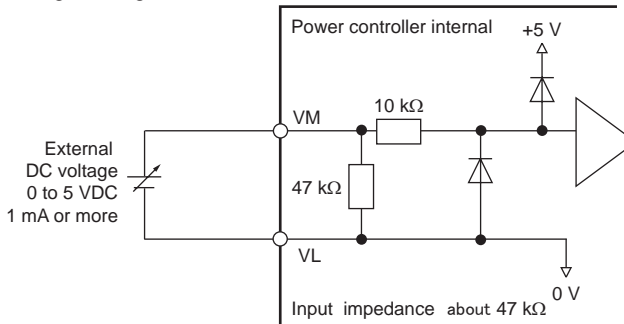

■ Using an external control equipment with a built-in clamp diode

If input signals are generated according to the sink logic and an external control device with built-in clamp diode is used, a sneak current path may be formed and the motor may operate even when the power to the external control device is cut off, as long as the power controller receives power. The motor may also run when the controller power and inverter power are turned on/off simultaneously, because the power capacity of the controller is different from that of the inverter.

When turning on the power, turn on the external control equipment power first, and then turn on the power controller power. When turning off the power, turn off the power controller power first, and then turn off the external control equipment power.

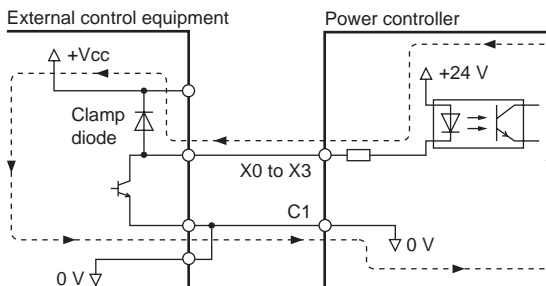

■ Output signal circuit

The power controller's alarm output signals are transistor open-collector outputs. The ON voltage of the output circuit is max. 1.6 V. When driving each element using the output signal circuit, give consideration to this ON voltage.

- Sink logic

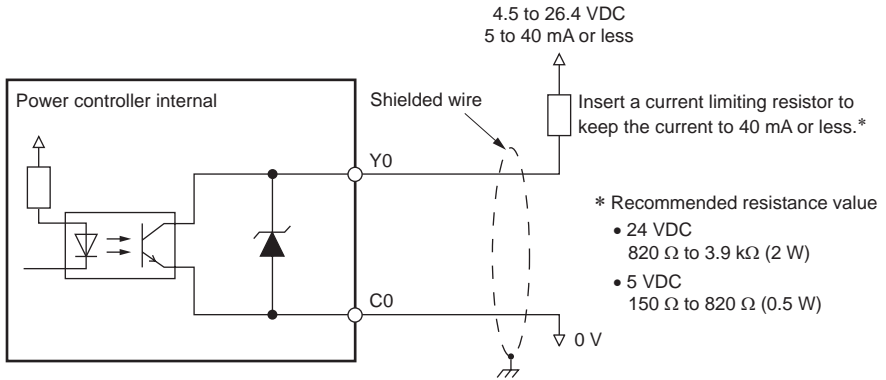

Y0: ALARM output

- Source logic

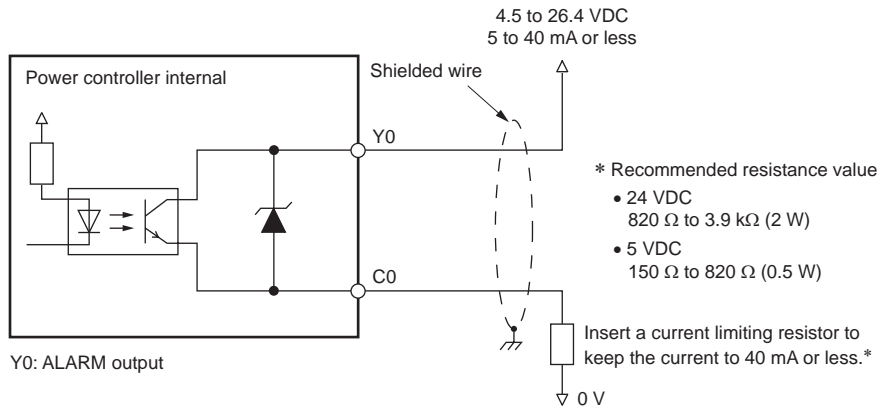

Y0: ALARM output

Note

- When connecting a relay (inductive load), etc., to detect alarm outputs, use a relay with built-in flywheel diode, or provide a fly-back voltage control measure based on diode, etc., for the inductive load.
- Be sure to connect a current limiting resistor. If the supply voltage is applied directly to the alarm output signal circuit without going through a power limiting resistor, the power controller will be damaged.

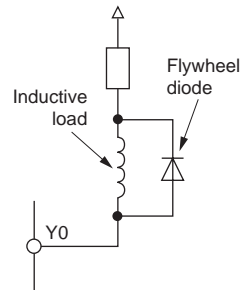

7 Operation

This chapter explains the basic operations of the power controller.

7.1 Basic operations

The method to set torque using the internal torque potentiometer is explained.

For the method to set torque using the external torque potentiometer or external DC voltage, refer to p.23.

Turn on the AC power and DC power, input CW or CCW, and then adjust the torque using the internal torque potentiometer. The ALARM LED will illuminate briefly when the DC power is turned on. This is not a malfunction.

- Running/stopping the motor and changing the motor direction

Check “7.3 Timing chart” for the action of the motor in response to the input signals or ON-OFF of the power supply.

Turn the CW input or CCW input ON to run the motor. Turn the input OFF, and the motor will stop. When the CW input is turned ON, the motor will rotate in the clockwise direction as viewed from the output shaft side of the motor. When the CCW input is turned ON, the motor will rotate in the counterclockwise direction as viewed from the output shaft side of the motor. If the CW input and CCW input are turned ON simultaneously, the motor will stop.

CW input	CCW input	Motor operation
ON	OFF	Operation (forward)
OFF	ON	Operation (reverse)
ON	ON	Stop

The signal state does not represent the voltage level of the signal. Rather, it represents the “ON (energized)” or “OFF (not energized)” state of the internal photocoupler.

Note

Insulation class of this motor is B. Make sure that the motor case temperature does not exceed 90 °C (194 °F) during operation of the motor. Operation exceeding case temperature 90 °C (194 °F) may significantly deteriorate the coils and ball bearings of the motor and shorten the motor's life span. Motor case temperature can be measured by fixing a thermometer on the motor surface. It can also be measured using thermo tape or a thermocouple.

- Rotating direction of the gearhead output shaft

The rotating direction of the gearhead output shaft may be opposite that of the motor shaft, depending on the gear ratio. Before performing wiring, be sure to check the rotating direction of the gearhead output shaft to be used and determine the desired direction of motor rotation.

Gearhead model	Gear ratio	
	Same as the rotating direction of motor shaft	Opposite the rotating direction of motor shaft
2GN□S, 3GN□S, 4GN□S, 5GN□S	3 to 18	25 to 36
	50 to 180	

- Torque adjustment

Turning the internal torque potentiometer in the clockwise direction will increase the torque. Turning it in the counterclockwise direction will decrease the torque. The factory setting is the minimum level (0).

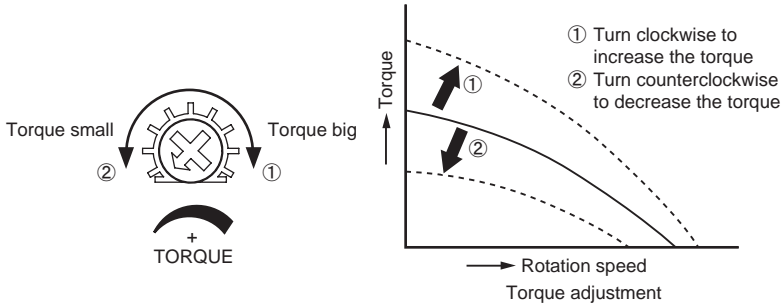

7.2 Torque setting using an external potentiometer or external DC voltage

- External torque potentiometer

The method to operate the motor using the external torque potentiometer (**PAVR-20KZ**) (sold separately) is explained. Refer to p.35 for the method to install **PAVR-20KZ**.

Set the external voltage selection switch to 5 V. The factory setting is 5 V.

External potentiometer

PAVR-20KZ

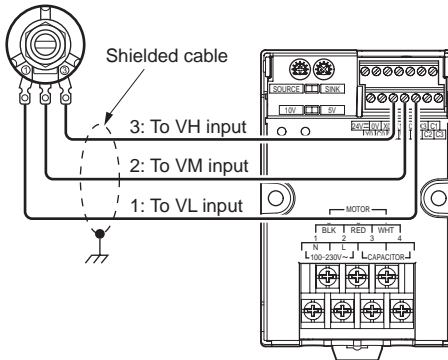

External torque potentiometer terminal	Power controller terminal
3	VH
2	VM
1	VL

1. Turn on the power.
2. Turn the input signal INT/EXT ON.
3. Turn the CW input or CCW input ON.
4. Adjust the torque using the external torque potentiometer.

Turning the external torque potentiometer dial in the clockwise direction will increase the torque. Turning it in the counterclockwise direction will decrease the torque.

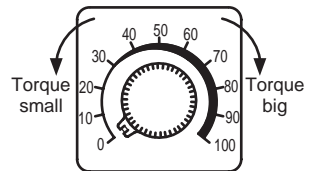

External potentiometer

Note | Set the external voltage switch to 5 V.

External DC voltage

Set the external voltage selection switch on the power controller in accordance with the voltage level (5 or 10 VDC) of the external DC power supply to be used. The factory setting is 5 V.

Use a DC power supply (5 or 10 VDC) with its primary and secondary circuits isolated by reinforced insulation.

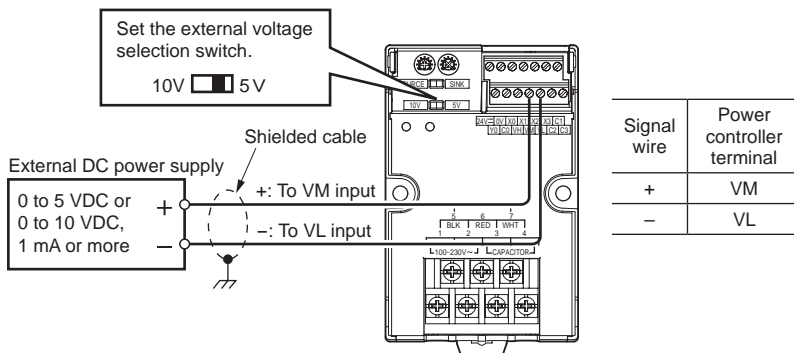

1. Set the 5/10 V selection switch to the 5 V or 10 V position. (Factory setting: 5 V)
2. Turn on the power.
3. Turn the input signal INT/EXT ON.
4. Turn the CW input or CCW input ON.
5. Adjust the torque using the external DC voltage.

Raising the external DC voltage will increase the torque, while lowering it will decrease the torque.

Note Do not switch the external voltage select (5 V, 10 V) switch while the controller power is supplied. Be sure to turn off the controller power before setting these switches.

External torque potentiometer graduation vs. torque ratio characteristics (representative values)

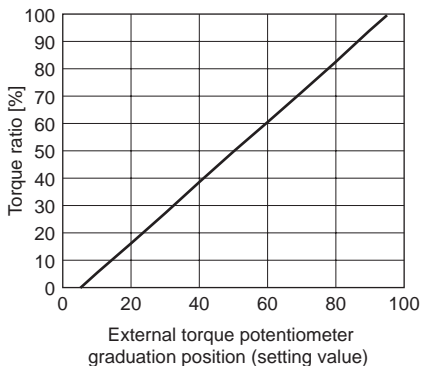

External DC voltage vs. torque ratio characteristics (representative values)

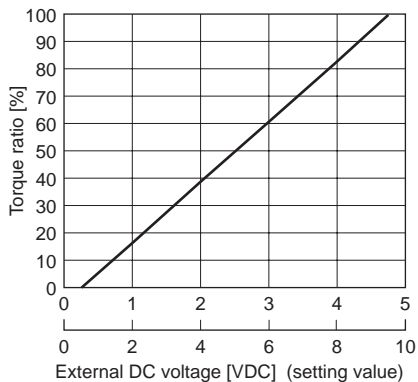

The above characteristics are representative values. Use them only as a reference when setting the torque.

- The torque ratio is set by the external torque potentiometer or external DC voltage, and indicates the percentage of the maximum torque (starting torque) applicable to each setting value. This ratio changes with the motor output and voltage. Refer to the catalog for details.

7.3 Timing chart

The rotating direction indicates the direction in which the motor shaft rotates as viewed from the output shaft side of the motor. (CW: Clockwise direction, CCW: Counterclockwise direction) Depending on the gear ratio of the gearhead, the rotating direction of the gear output shaft may become opposite to the direction of the motor. The signal state does not represent the voltage level of the signal. Rather, it represents the “ON (energized)” or “OFF (not energized)” state of the internal photocoupler.

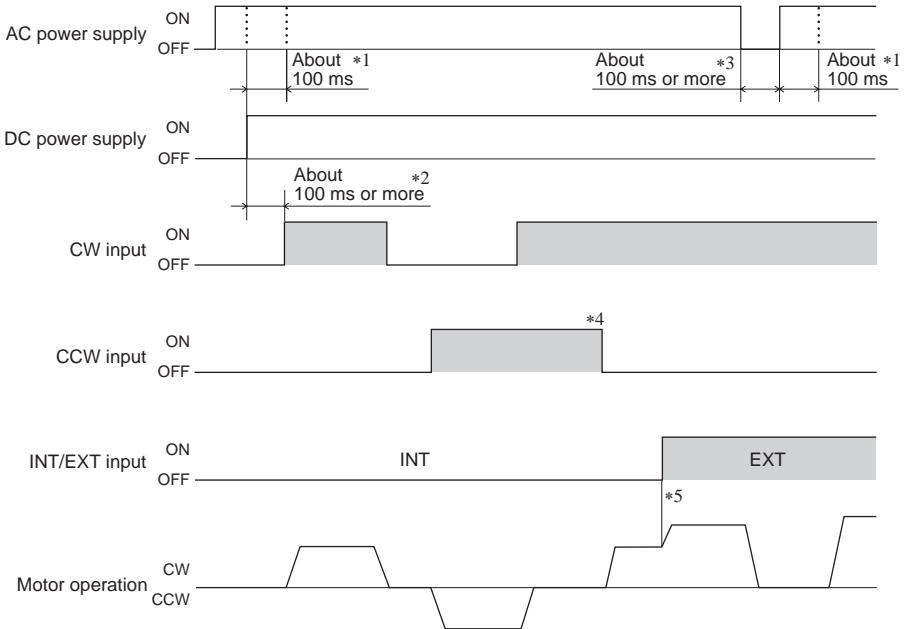

*1 When both the AC power and DC power are turned on, the power controller will check the AC power frequency (50 Hz or 60 Hz). If the AC power is turned off while the AC power frequency is being checked, motor operation will become unstable at the next driving. When motor operation is unstable, once turn off the AC power and DC power and turn on again.

*2 After the AC power and DC power are supplied, wait at least approximately 100 ms before operating the motor. The AC power or DC power can be turned on in any order.

*3 Do not change the AC power frequency once the AC power and DC power have turned on. If the power frequency is changed from the frequency confirmed when both powers were turned on, the power controller may malfunction. When changing the AC power frequency, do so after turning off the AC power (for at least 100 ms).

*4 If the CW input and CCW input are turned ON simultaneously, the motor will stop.

*5 Immediate two-step torque switching becomes possible by means of using the INT/EXT input signal to switch between the value set with the internal torque potentiometer and one set with the external torque potentiometer.

Note Do not turn off the AC power for at least approximately 100 ms after both the AC power and DC power are turned on.

7.4 Parallel operation

When two or more motors are to be operated at the same torque, you can do so by using either external DC voltage or the external torque potentiometer.

■ Using external DC voltage

- Use a DC power supply whose current capacity is equal to or greater than the value calculated by the formula below: Current capacity I when N number of power controllers are used = $1 \times N$ (mA)
[Example] If there are two power controllers, the power capacity should be equal to or greater than 2 mA.
- Connect other I/O signals to each power controller.
- Any difference in torque among the motors can be fine-tuned using the torque fine-tuning potentiometer.

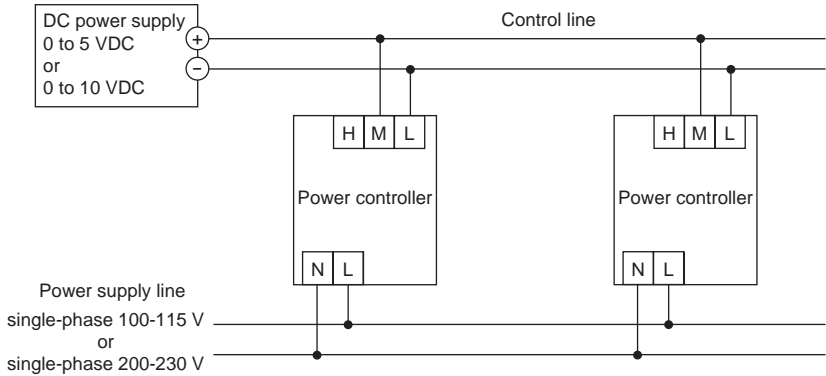

■ Using the external torque potentiometer

- As shown below, use the power line and torque control line in common and set torque using VRx.
Calculate the resistance of the external torque potentiometer as follows:
Resistance VRx when N number of power controllers are used = $20/N$ (k Ω), $N/4$ (W)
[Example] If there are two power controllers, the resistance should be 10 k Ω , 1/2 W.
- Connect other I/O signals to each power controller.
- Any difference in torque among the motors can be fine-tuned using the torque fine-tuning potentiometer.
- Keep the number of five or less in parallel operation using an external torque potentiometer.

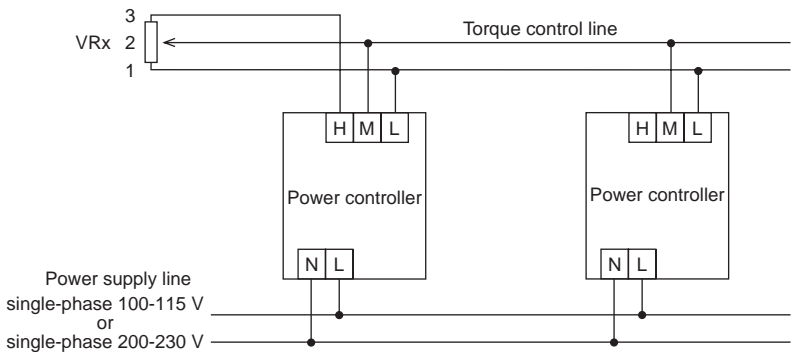

7.5 Adjustment using the torque fine-tuning potentiometer

The actual torque generated in response to the torque command varies slightly depending on the individual differences of the power controller, torque motor and capacitor used.

If you want to eliminate this variation, you can do so by fine-tuning the torque using the torque fine-tuning potentiometer (ADJUST). The factory setting is the middle level.

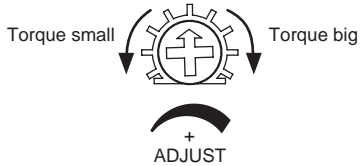

Turn the torque fine-tuning potentiometer to the right to increase the torque, and turn it to the left to decrease the torque.

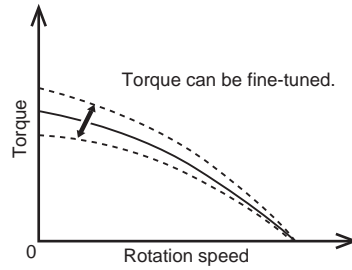

8 Alarm output

8.1 Alarm output signal circuit

The alarm function monitors the electrical current flowing through the motor in order to detect an actuation of the built-in thermal protector of the motor. This alarm function will actuate in the following conditions:

- The built-in thermal protector of the motor has actuated (become open).
- Improper motor cable connection or wire breakage.

Upon occurrence of either of the above conditions, the alarm output will turn OFF and the ALARM LED will blink (output to the motor will stop).

The ALARM LED will illuminate briefly when the DC power is turned on. This is not a malfunction.

The alarm output signals of this inverter are open-collector outputs. Therefore, an external power supply is needed to operate the output signals. Use an external power supply with a voltage range not exceeding 26.4 V, and connect a limiting resistor appropriate for the power supply voltage so as not to cause the current to exceed 40 mA. No external power supply is required if the output signals are not used. The output circuit terminals are insulated to the reinforced insulation standard for protection against dangerous voltages.

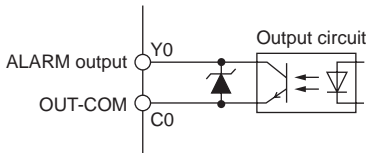

The ALARM output remains ON when the inverter is normal, and turns OFF when an alarm generates (normally closed).

The signal state does not represent the voltage level of the signal. Rather, it represents the “ON (energized)” or “OFF (not energized)” state of the internal photocoupler.

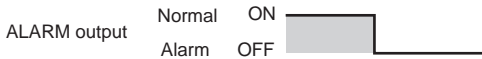

• ALARM RESET input

When an alarm is generated, in most cases it will be automatically reset by an appropriate protective function of the power controller.

Turn the CW input and CCW input OFF. After confirming that the motor has stopped completely, remove the cause of the alarm and then turn the alarm reset input ON for at least 10 ms.

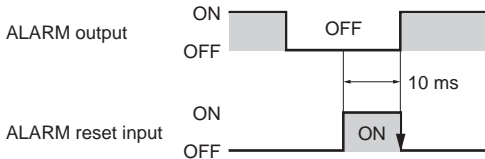

An alarm can also be reset by turning the DC power off and then turning it back on. If this method is used, however, turn OFF the CW input and CCW input first, as you would before inputting the alarm reset signal, before cycling the DC power.

Note

- Always input an alarm reset signal after removing the cause of the alarm.
- Inputting an alarm reset signal while a run signal is input will not reset the alarm. The ALARM RESET input is enabled only while the motor is stopped.

8.2 Timing chart

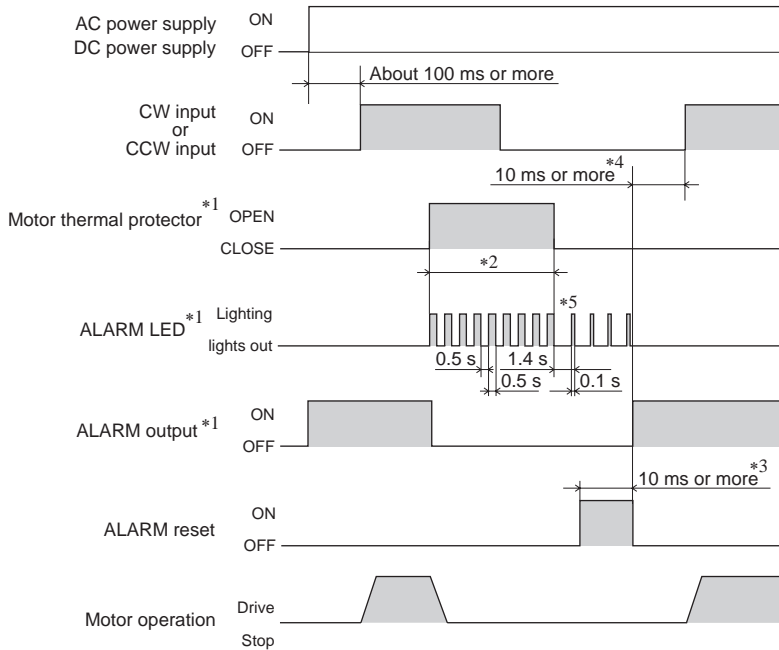

*1 When the built-in thermal protector of the motor actuates (becomes open), the alarm output will turn OFF and the ALARM LED will also blink.

Thermal protector activation range

Power is turned off..... 130±5 °C (266±9 °F)

Power is turned back..... 3 W 90±15 °C (194±27 °F), 6 to 20 W 82±15 °C (180±27 °F)

*2 While the built-in thermal protector of the motor remains actuated (open), the ALARM LED blinks at a short frequency. Once the thermal protector is reset (becomes closed), the blinking frequency will become long.

*3 To reset an alarm, do so after turning the CW input or CCW input OFF. The alarm reset input will become effective when the input is reset (OFF), provided that the input has remained ON for at least 10 ms.

Alarms cannot be reset while the CW input or CCW input is ON.

*4 To restart the motor after resetting an alarm, wait for at least 10 ms and then turn the run command input ON.

*5 If an alarm output generates due to actuation (opening) of the built-in thermal protector of the motor, keep the AC power on. This way, the blinking speed of the ALARM LED will slow once the thermal protector has been reset (closed), which shows that thermal protector has been reset.

If the alarm is not reset, the CPU may be experiencing an error. In this case, turn the run command input OFF and then cycle the DC power.

9 Switching between sink logic and source logic

Remove the case cover to access the SINK/SOURCE input selector switch used for changing the input signal circuit. The factory setting is sink logic (SINK).

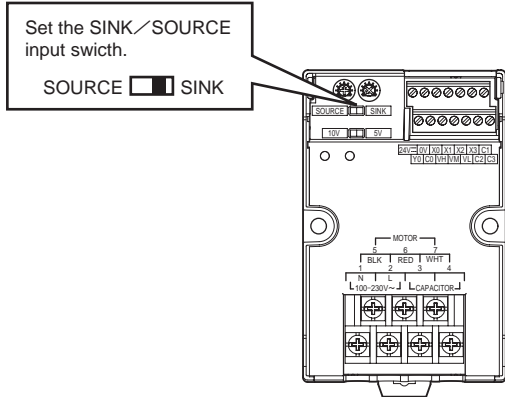

Note Do not change the SINK/SOURCE input selector switch while the controller is receiving power. Always change this switch after turning off the controller power.

■ Connection example of input circuit (sink input)

When relays and other contact switches are used

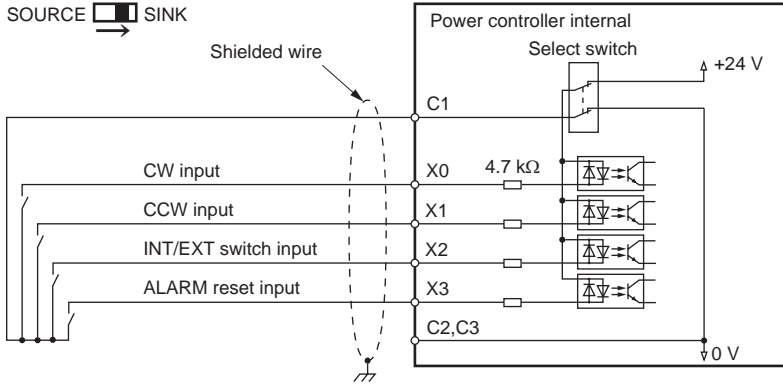

When transistors and other non-contact switches are used

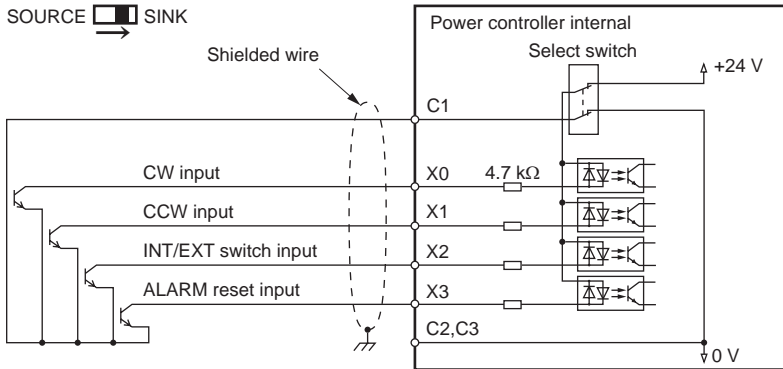

■ Connection example of input circuit (source input)

- When relays and other contact switches are used (Using an internal power supply)

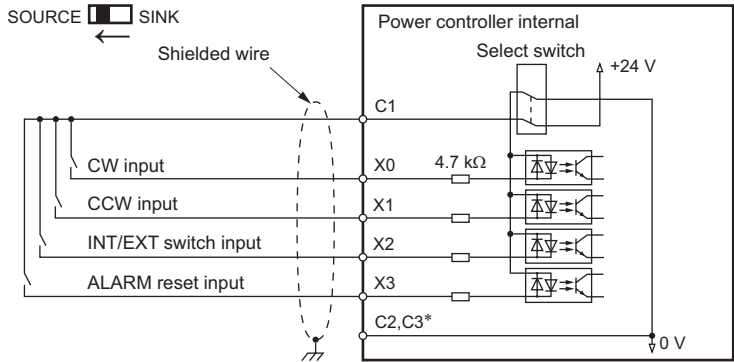

* Do not connect anything to C2 and C3 terminal.

- When relays and other contact switches are used (Using an external power supply)

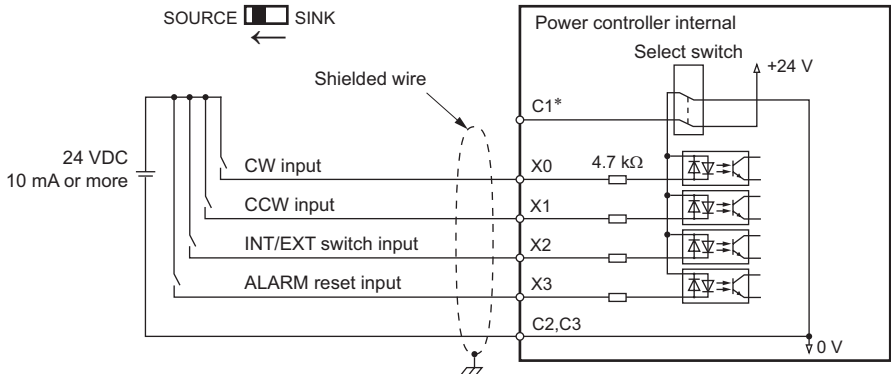

* C1 outputs an internal supply voltage of +24 V. Do not connect anything to this terminal. Connect the ground of external power supply to C2 and C3.

- When transistors and other non-contact switches are used

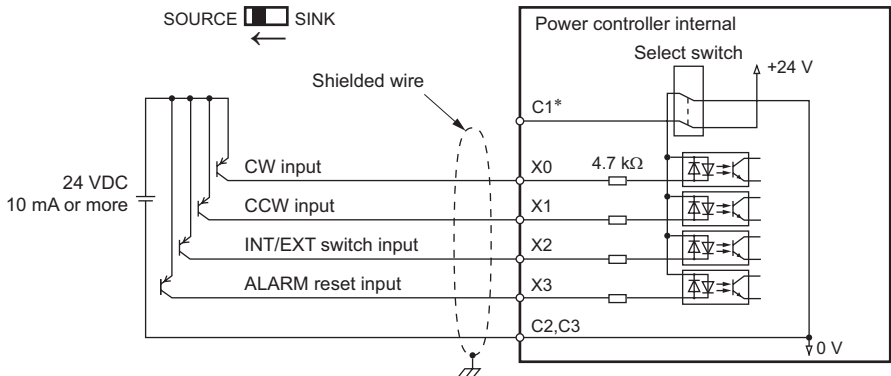

* C1 outputs an internal supply voltage of +24 V. Do not connect anything to this terminal. Connect the ground of external power supply to C2 and C3.

10 Inspection

It is recommended that the items listed below be inspected regularly after motor operation. If any abnormality is found, stop using the motor and call our Technical Support Line.

Note

- Do not conduct the insulation resistance measurement or dielectric strength test with the motor and power controller connected. Doing so may cause damage to the product.
- The power controller uses semiconductor elements, so handle it with due care. Electrostatic can damage the power controller.

■ Inspection items

- Check if any of the mounting screws of the motor and gearhead are loose.
- Check if the bearing part (ball bearings) of the motor generates unusual noises.
- Check if the bearing part (ball bearings) or gear meshing part of the gearhead generates unusual noises.
- Check if the output shaft of the motor and gearhead and a load shaft are out of alignment.
- Check if a damage or stress is applied on the cable or the connection part between the cable and power controller is loose.
- Check if the openings in the power controller causes clogging.
- Check if the mounting screws of the power controller as well as screws of the main-circuit connection terminals and control circuit terminals are not loose.
- Check if the power controller generates unusual smells or has foreign objects inside.

11 Troubleshooting and remedial actions

An erroneous torque setting or connection may prevent the motor/power controller from operating properly. If proper motor operation cannot be achieved, take an appropriate action by referring to this chapter. If the information provided here does not help, please call our Tech Support Line.

■ Troubleshooting

Phenomenon		Likely cause	Remedial action
The motor does not run.	The ALARM LED is not blinking.	Both the CW and CCW inputs are ON.	Turn either the CW input or CCW input ON.
		Both the CW and CCW inputs are OFF.	
		Error in the motor's lead connection.	Check the connection.
		The capacitor is not connected.	
	Wrong input signal line connection.	Reconsider the power lines or take measures such as using the AC line filter (p.11), and apply a stable power supply voltage.	
Distortions are being occurred in voltage waveforms of the AC power supply. Or the product is being affected by electrical noise.			
The ALARM LED is blinking.	The built-in thermal protector of the motor has actuated.	Check the operating conditions to see if the motor is used in conditions beyond its specifications.	
Motor run is unstable.		The centers of the motor' output shaft and load shaft are not aligned.	Check the connection condition of the motor (gearhead) output shaft and load shaft.
		Electrical noise.	Check the operation by connecting the motor and power controller only. If effect of noise is detected, take appropriate measures such as isolating the motor/controller from noise sources, reviewing the wiring, using a mains filter, and so on. (Refer to p.11.)
The motor rotates in the direction opposite that which is specified.		Wrong motor cable connection.	Check the connection.
		Wrong direction input.	Input the correct direction signal. The motor rotates in the CW direction when the CW input is ON, and in the CCW direction when the CCW input is ON.
		A gearhead whose rotating direction is opposite the direction of the motor is used.	Reverse the direction inputs.
The alarm reset input does not work.	The ALARM LED continues to blink.	The alarm reset input was turned ON while a run signal was being input.	Turn the alarm reset input ON after turning the CW input or CCW input OFF.
		The alarm reset input has not remained ON for a sufficient period of time, or the input remains ON.	Turn the alarm reset input ON for at least 10 ms, and then turn it OFF.
	The ALARM LED is illuminating steadily.	The built-in thermal protector of the motor remains actuated (open).	<ul style="list-style-type: none"> Cool the motor temperature until the thermal protector is reset (becomes closed), or wait for the motor temperature to drop to this level. (Refer to p.29.) Check the operating conditions to see if the motor is used in conditions beyond its specifications.
		CPU abnormal.	Turn the CW input or CCW input OFF, and then cycle the DC power. If the product does not operate properly after the control DC power supply is cycled, internal circuit damage is suspected. Contact your nearest Oriental Motor sales office.

12 Peripheral equipment (sold separately)

■ External torque potentiometer

This external potentiometer consists of a variable resistor, insulation sheet, dial plate and dial.
Model: **PAVR-20KZ**

• How to Install the external torque potentiometer **PAVR-20KZ**

Insert the external potentiometer as shown below.

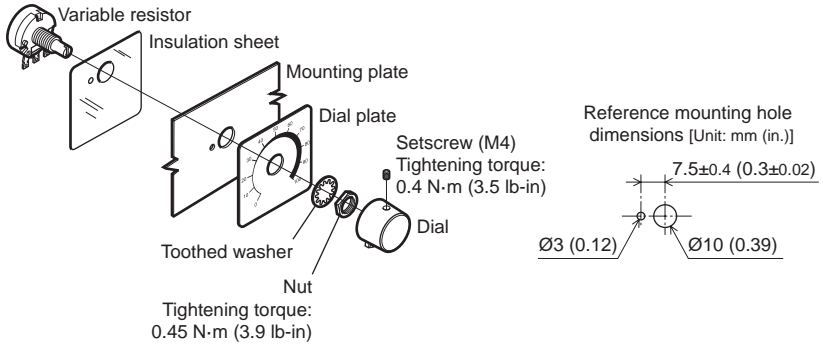

• Soldering the variable resistor terminal

Cover a heat-shrinkable tube over the soldered part to insulate.
Soldering condition: 235 °C (455 °F), less than 5 sec.

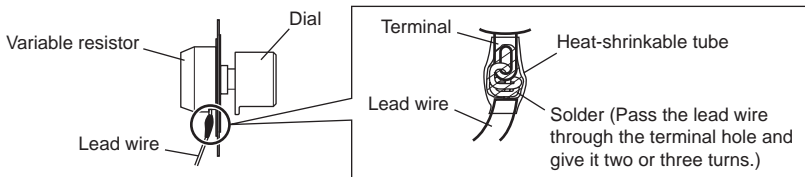

- Unauthorized reproduction or copying of all or part of this manual is prohibited.
If a new copy is required to replace an original manual that has been damaged or lost, please contact your nearest Oriental Motor branch or sales office.
- Oriental Motor shall not be liable whatsoever for any problems relating to industrial property rights arising from use of any information, circuit, equipment or device provided or referenced in this manual.
- Characteristics, specifications and dimensions are subject to change without notice.
- While we make every effort to offer accurate information in the manual, we welcome your input. Should you find unclear descriptions, errors or omissions, please contact the nearest office.
- **Orientalmotor** is a registered trademark or trademark of Oriental Motor Co., Ltd., in Japan and other countries.
Other product names and company names mentioned in this manual may be registered trademarks or trademarks of their respective companies and are hereby acknowledged. The third-party products mentioned in this manual are recommended products, and references to their names shall not be construed as any form of performance guarantee. Oriental Motor is not liable whatsoever for the performance of these third-party products.

© Copyright ORIENTAL MOTOR CO., LTD. 2017

Published in March 2021

• Please contact your nearest Oriental Motor office for further information.

ORIENTAL MOTOR U.S.A. CORP.
Technical Support Tel:800-468-3982
8:30am EST to 5:00pm PST (M-F)
www.orientalmotor.com

ORIENTAL MOTOR (EUROPA) GmbH
Schiessstraße 44, 40549 Düsseldorf, Germany
Technical Support Tel:00 800/22 55 66 22
www.orientalmotor.de

ORIENTAL MOTOR (UK) LTD.
Tel:+44-1256347090
www.oriental-motor.co.uk

ORIENTAL MOTOR (FRANCE) SARL
Tel:+33-1 47 86 97 50
www.orientalmotor.fr

ORIENTAL MOTOR ITALIA s.r.l.
Tel:+39-02-93906347
www.orientalmotor.it

ORIENTAL MOTOR ASIA PACIFIC PTE. LTD.
Singapore
Tel:1800-842-0280
www.orientalmotor.com.sg

ORIENTAL MOTOR (MALAYSIA) SDN. BHD.
Tel:1800-806-161
www.orientalmotor.com.my

ORIENTAL MOTOR (THAILAND) CO., LTD.
Tel:1800-888-881
www.orientalmotor.co.th

ORIENTAL MOTOR (INDIA) PVT. LTD.
Tel:1800-120-1995 (For English)
1800-121-4149 (For Hindi)
www.orientalmotor.co.in

TAIWAN ORIENTAL MOTOR CO., LTD.
Tel:0800-060708
www.orientalmotor.com.tw

SHANGHAI ORIENTAL MOTOR CO., LTD.
Tel:400-820-6516
www.orientalmotor.com.cn

INA ORIENTAL MOTOR CO., LTD.
Korea
Tel:080-777-2042
www.inaom.co.kr

ORIENTAL MOTOR CO., LTD.
4-8-1 Higashiueno, Taito-ku, Tokyo
110-8536 Japan
Tel:+81-3-6744-0361
www.orientalmotor.co.jp